

*ADT-C Series*

---

**Digital Torque Meter  
ADT-C Series**

OPERATION MANUAL

**Ottonic**

---

*ATTONIC*

## ■ Digital Torque Meter

It is the torque-measuring instrument of the electronic formula which can measure torque power. It corresponds to a large area from the field of a quality control to the research and development. Our Digital Torque Meters are used well to check intensity or movement of some parts in automobile industry, electric industry and etc.

## ■ Features

- Our Digital Torque Meter has original design.
- Sampling Speed 1ms
- The digital range of display is max. 9999.
- Digimatic, Analog, RS-232C and Comparator out-put are attached as standard accessory.

## ■ Example Use

- Peak Holding Measurement and Tracking Measurement
- Peak Holding Memory is 50 Measurements Value.
- The limit of H I (HIGH) and L O (LOW) can be made by comparator out-put.
- Selectable 3 units (N·m, Kg f·cm, in·lbf)
- Battery Volume can be checked on display.
- Power auto-off function.  
When there is no key 5 minutes, a power supply is turned off automatically.

## ■Notes



### Do not overload

The limit of overload capacity is 120% of full scale. When the load is reached to 110% of Full Scale, “ OVER LOAD ” is indicated on display. Keep it within 100% of Full Scale. This is the cause for the breakdown of load sensor.

※In case of over load setting 1~100 %, “ OVER LOAD ” will be indicated on display when the load is reached over your setting value. (Regarding over load setting, please see page No.9.)



### Do not use other adapter

Should other adapter be used, there are possibility to breakdown or may lead to a fire. Also, do not charge or operate unit in other voltage.



### Do not impact or damage unit

This is the cause for the breakdown of load sensor or other troubles.



### Do not store and operate in the following conditions

- ※ Wet area                    ※ Where dew condensation
- ※ Dusty area                ※ Where oil or chemicals



### Do not disassemble, trouble-shoot and remodel

Should you perform any of these, that may cause malfunction of the unit.

## ■ Specifications

### ■ Standard Specifications

- Measuring Unit : Selectable 3 units N·m(N·cm)/Kgf·cm/in·lbf
- Accuracy :  $\pm 0.5\%$  of F/S
- Measurement : Peak Holding / Tracking
- Peak Holding : Digital Peak Holding
- Peak Holding Memory : 50 Measurement Values
- Sampling Speed : 1ms
- Display : 4 digits LCD
- Over Load Capacity : 120%
- Auto Power Off Term : 5 minutes
- Attachment : Please refer page No.5 and 6.
- Net Weight : About 3.2 kg
- Guarantee : 1 year
- Power Supply : Rechargeable Ni-MH Battery  
(Charging Time : About 4 hours)
- Out-Put : ①Digimatic out-put ②RS-232C out-put  
③Reset signal in-put ④Comparator out-put  
⑤ Analogue out-put ( $\pm 1V$ )

\*Regarding the details for out-put, please refer page No.13.

## ■ Model & Indication Range

MODEL	Measuring Range
	Min. Indication
ADT-C1	1.000-9.999N·cm/0.100-1.000Kgf·cm/0.100-1.000in·lbf
	0.001N·cm/0.001Kgf·cm/0.001in·lbf
ADT-C2	2.00-20.00N·cm/0.200-2.000Kgf·cm/0.200-2.000in·lbf
	0.01N·cm/0.001Kgf·cm/0.001in·lbf
ADT-C5	5.00-50.00N·cm/0.500-5.000Kgf·cm/0.500-5.000in·lbf
	0.01N·cm/0.001Kgf·cm/0.001in·lbf
ADT-C10	0.100-0.999N·m/1.000-9.999Kgf·cm/1.000-9.999in·lbf
	0.001N·m/0.001Kgf·cm/0.001in·lbf
ADT-C20	0.200-2.000N·m/2.00-20.00Kgf·cm/2.00-20.00in·lbf
	0.001N·m/0.01Kgf·cm/0.01in·lbf
ADT-C50	0.500-5.000N·m/5.00-50.00Kgf·cm/5.00-50.00in·lbf
	0.001N·m/0.01Kgf·cm/0.01in·lbf
ADT-C100	1.000-9.999N·m/10.00-99.99Kgf·cm/10.00-99.99in·lbf
	0.001N·m/0.01Kgf·cm/0.01in·lbf
ADT-C200	2.00-20.00N·m/20.0-200.0Kgf·cm/20.0-200.0in·lbf
	0.01N·m/0.1Kgf·cm/0.1in·lbf

- 1 In case of 100% to 110% of full scale of measuring range, the display indicate the measuring value. However this measuring value can not be used for your measurement. In case of 110% over, "OVER LOAD" is indicated on display. (This is in case of over load setting "0")

※In case of over load setting 1 ~ 100 %, "OVER LOAD" will be indicated on display when the load is reached over your setting value. (Regarding over load setting, please see page No. 9.)

## ■ Standard Attachments for each model

Model No.	Standard Accessories (each 1 pce.)
ADT-C 1	TC-2、TSS-5
ADT-C 2	TC-2、TSS-5
ADT-C 5	TC-2、TSS-5
ADT-C 10	TC-3、TSS-10
ADT-C 20	TC-3、TSS-20
ADT-C 50	TC-6、TSS-30
ADT-C 100	TC-4、TSS-30
ADT-C 200	TC-4、TSS-30

• Attachments

■ **ADT-C 1、2、5**

**TC-2**  
(M3Screw/#2)

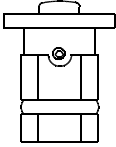

**TSS-5**  
(M3Screw/#2+With Spring)  
0. 1 ~ 0. 5 N · m

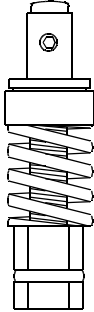

TSS-5 :  
Screw is a replacement formula.  
Screw of the side is loosened.  
\* Reserve : Two screws each are attached.

■ **ADT-C 10**

**TC-3**  
(M4Screw/#2)

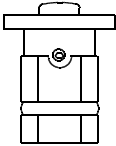

**TSS-10**  
(M4Screw/#2+With Spring)  
0. 2 ~ 1 N · m

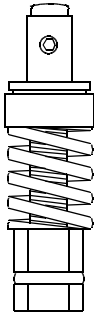

TSS-10 :  
Screw is a replacement formula.  
Screw of the side is loosened.  
\* Reserve : Two screws each are attached.

■ ADT-C20

**TC-3**  
(M4Screw/#2)

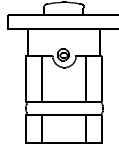

**TSS-20**  
(M5Screw/#2+With Spring)  
0.5 ~ 2 N · m



TSS-20 :  
Screw is a replacement formula.  
Screw of the side is loosened.  
\* Reserve : Two screws each are attached.

■ ADT-C50

TC-6  
(M5Screw/#2)

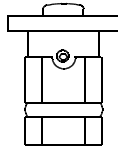

TSS-30  
(M6Screw/#3+With Spring)  
O. 5~3 N·m



TSS-30 :  
Screw is a replacement formula.  
Screw of the side is loosened.  
\* Reserve : Two screws each are attached.

■ ADT-C100、200

TC-4  
(M6Screw/#3)

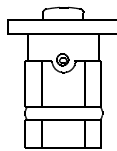

TSS-30  
(M6Screw/#3+With Spring)  
O. 5~3 N·m



TSS-30 :  
Screw is a replacement formula.  
Screw of the side is loosened.  
\* Reserve : Two screws each are attached.

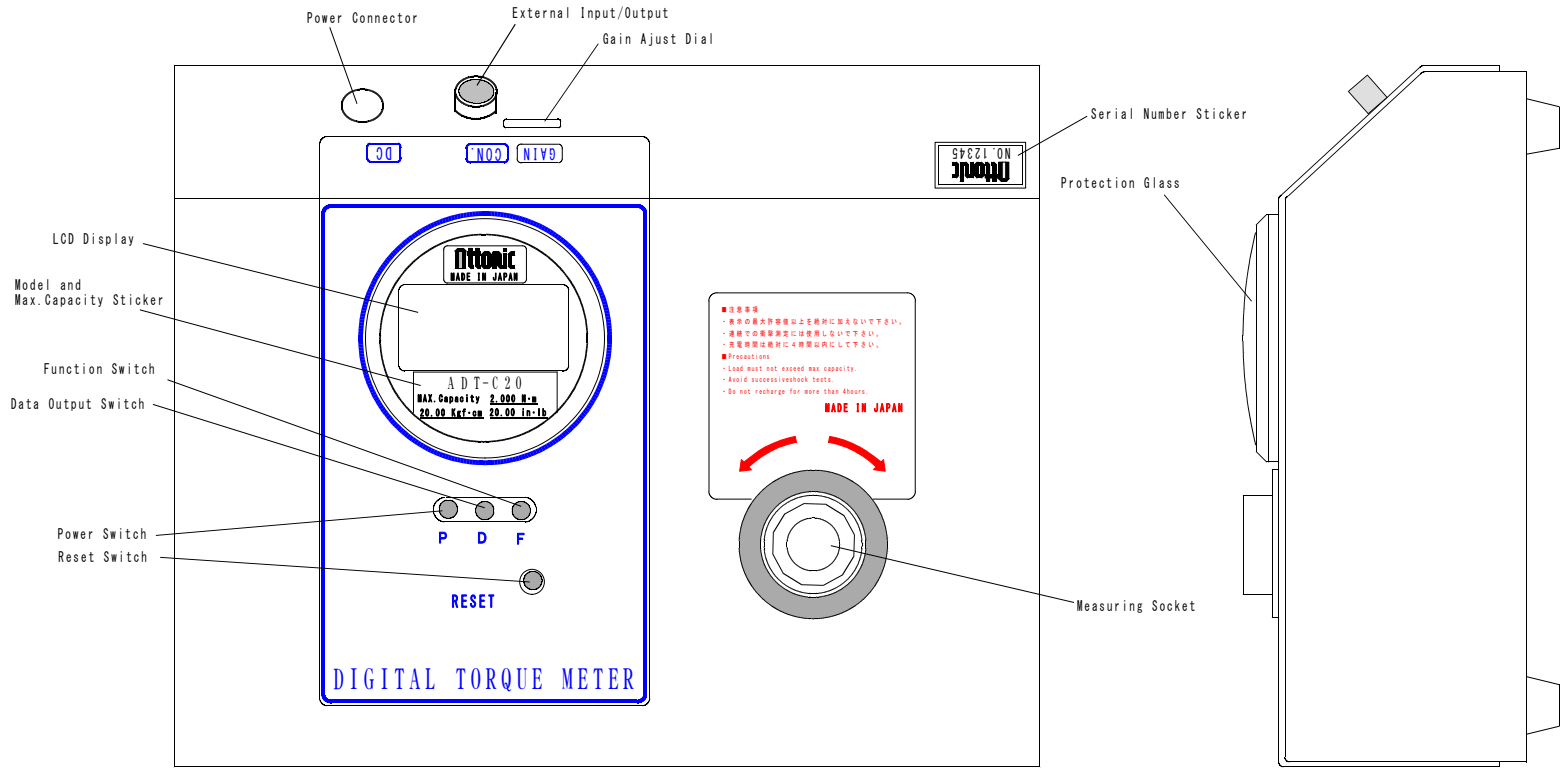

## ■ Explanation of each parts (1)

### ▪ EXTERNAL INPUT / OUTPUT (CON.)

It is possible to do the various outside output and display reset from outside. For details, see the explanation of the output connector page No. 9.

### ▪ POWER CONNECTOR (DC)

Insertion connector of AC adapter for the charging. The standard recharging time is about 4 hours after making a power off. The charging condition can be confirmed by display when making a power on. Also, it can be used inserting AC adapter. However, it becomes the cause which hastens the degradation of the charging battery. Recommend to use without using AC adapter as much as possible.

### ▪ GAIN ADJUST DIAL

ONLY MANUFACTURE SIDE (NEVER CHANGE THIS DIAL)

It is used when the calibration at the manufacture.

### ▪ LCD DISPLAY

Using graphic LCD (liquid crystal), it is possible to show a feature character, setting character, numbers and charging scale in the display.

### ▪ PROTECTION GLASS

Digital display is covered by protection glass.

### ▪ MODEL AND MAX. CAPACITY STICKER

Model number and maximum display value of 3 units and indicated.

### ▪ POWER SWITCH (P)

On/Off button of the power. The buzzer sounds in case of start the operation.

### ▪ DATA OUTPUT SWITCH (D)

Output button for the digimatic signal and RS-232C signal of the data. It outputs a digital signal firstly and it outputs a RS-232C signal.

### ● (Caution)

It outputs the digital signal when using a functionfeature. Also, in case of function feature (FU), it can be changed Peak Hold and Tracking, the reading of memory data and various setting of value.

## ■ Explanation of each part(2)

- **FUNCTION SWITCH (F)**

This button is for setting up each function. To change function mode, keep to push about 6 seconds. (“FU” is indicated in LCD Display), can be set up each function.

- **RESET SWITCH**

This button is for resetting data indication of peak-hold and tracking.

Besides when the mode is function (FU), you can reset all of the memory data (but cannot reset the data one-by-one), and can alter the figure (then the figure is underlined) by this button.

- **SERIAL NUMBER STICKER**

Serial number is mentioned on this sticker.

- **MEASURING SOCKET**

Attachment should be set on this measuring socket.

## ■ Explanation of a button setting function (1)

Various functional set up in button operation.

● Set up the function

- ① Change Peak Hold (PEAK) and Tracking (TRUCK)
- ② Check Memory (MO) Data and Elimination of all memory data
- ③ Set up Comparator Function (HI)
- ④ Set up Comparator Function (LO)
- ⑤ Change Measuring Unit (UN)
- ⑥ Set up Over Load (OV)
- ⑦ Set up Power Auto Off (AP)
- ⑧ Set up Number of Digits on display / NP setting
- ⑨ Reverse Digital Display

Power switch is turned ON while pressed the P-button. (Becomes MEASUREMENT MODE)

(When there is no key 2-3minutes, a power supply is turned off automatically)

Keep to push F button about 6 seconds, indicate by FU unction). (Becomes SETTING MODE)

Preparations the various setting were completed.

The programming procedure after FU display

① Change Peak Hold (PEAK) and Tracking (TRUCK)

Change the Peak hold (PEAK) and change the tracking (TRUCK) when pressed the D button. (Initial setting : TRACK)

↓

Push F button

② Check Memory (MO) Data and Elimination of all memory data

" MO " in the upper right side of the display. Can be confirmed the memory date. The memory data is advanced when press the D button. (from MO1 up to M50)

Elimination of all memory data should press the RESET button.

(Each data is not eliminable)

The display indicate MO 0 when data is eliminated. (Initial setting : 0)

↓

Push F button

③ Set up Comparator Function (HI)

Set up the upper limit of comparator function Figure rising by D-button and Digit rising by RESET-button. When not using this function, setting to the 0. (Initial setting : 0)

↓

## ■ Explanation of a button setting function (2)

Push F button

### ④ Set up Comparator Function (LO)

Set up the low limit of comparator function. Figure rising by D-button and Digit rising by RESET button. When not using this function, setting to the 0.  
(Initial setting : 0)

↓

Push F button

### ⑤ Change Measuring Unit (UN)

To push D button, display change from N → K g f → lb f → N...  
(Initial setting : N)

↓

Push F button

### ⑥ Set up Overload (OV)

Count up by D button. Figure up by RESET button. Setting value is %. It cannot set under 0. When not using this function, setting to the 0.  
(Initial setting : 0)  
In case of setting 0, "OVER LOAD" will be indicated on display when the load is reached from 100% to 110% of full scale.

↓

Push F button

### ⑦ Set up Power Auto Off (AP)

To push D button, Set up the Power auto off 1 → release 0...  
(Initial setting : 1)

↓

Push F button

### ⑧ Set up Number of Digits on display / NP setting (NP)

Push "D" button.  
If you need 3 digits on display, please set "1".  
If you need 4 digits, please set "2".  
It is possible to change number of digits by this function.

↓

Push F button

### ⑨ Reverse Digital Display

The Value becomes flashing & dark.  
To push D button, the direction of display indication is reversed in upside down position.

↓

Push F button

### TO ① Change Peak Hold (PEAK) and Tracking (TRUCK)

Keep to push F button about 6 seconds, the gauge is now ready to measure.

## ■Digital indication for function mode

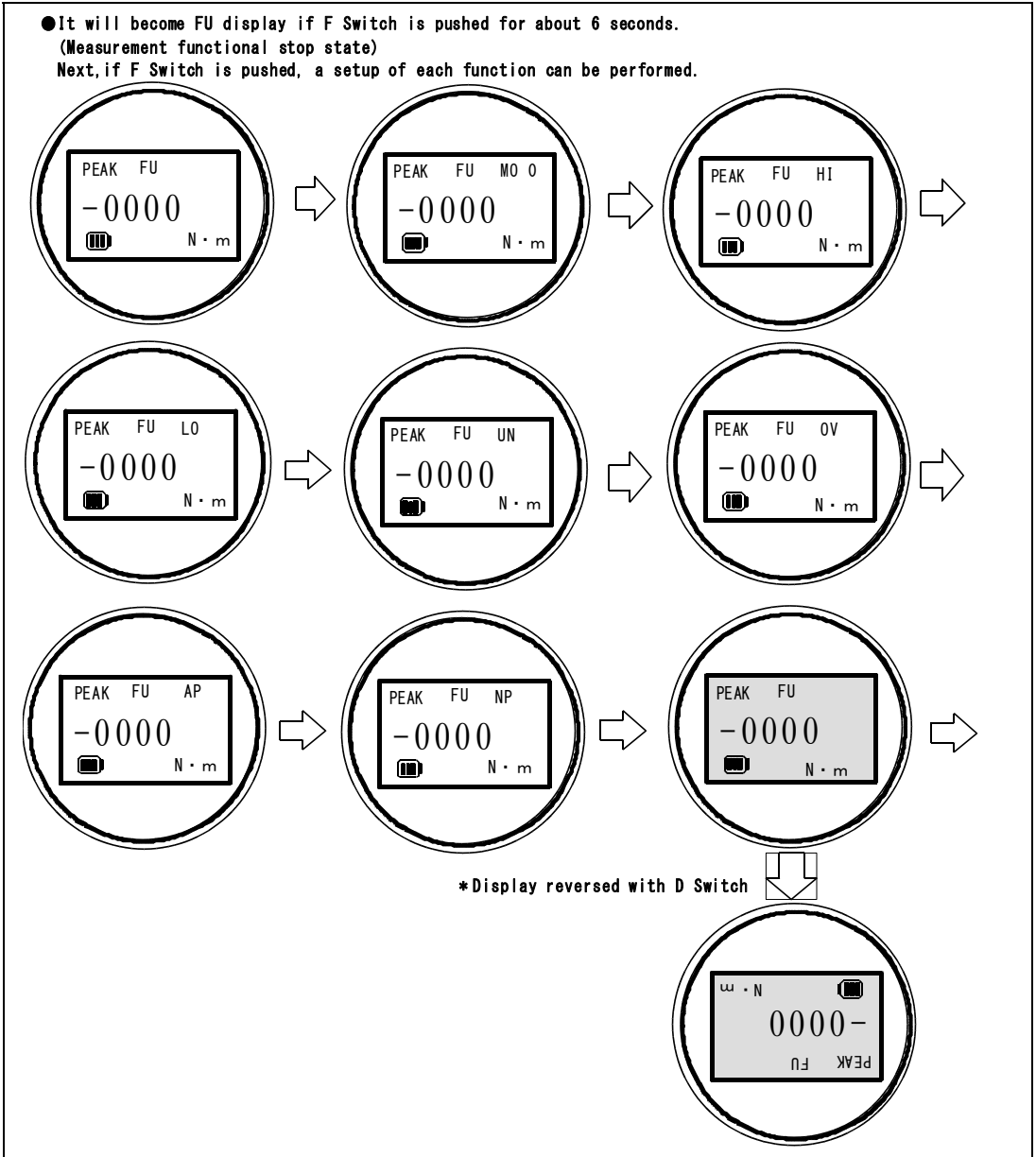

## ■Digital indication for warning messages

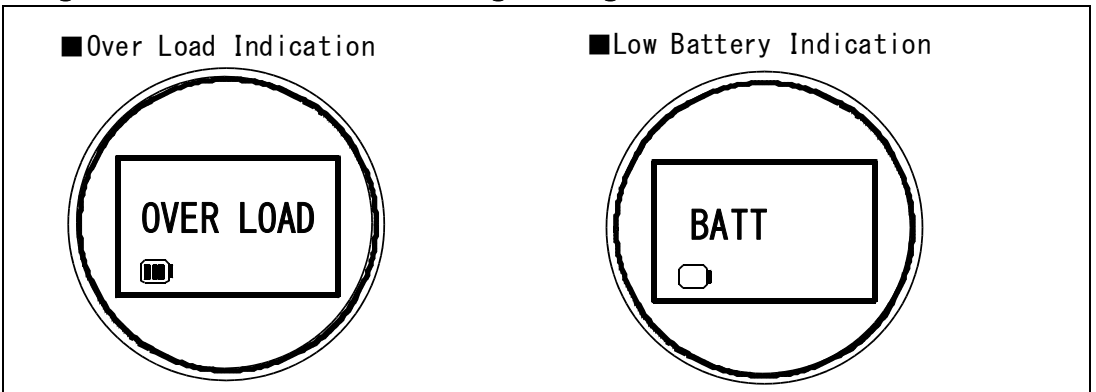

## ■ External Input / Output

\* Connector of HIROSE brand HR25-9TR-16S is used. (16 pins)  
Please prepare a plug HR25-9TP-16P.

Name of signal for each connector pin is as follows.

1. Analog output ...  $\pm 1V$
2. Analog GND
3. Signal input for External reset... Indication reset
4. Input COM
5. Comparator HI ... Open Collector Output (50V / 100mA)
6. Comparator GO ... "
7. Comparator LO ... "
- 8.
9. Output COM
10. RS-232C Rx ... Please refer the following RS-232C Format
11. RS-232C Tx ... "
12. Digimatic output (DATA)
13. Digimatic output (CK)
14. Digimatic output (RD)
15. Digimatic output (REQ)
16. GND

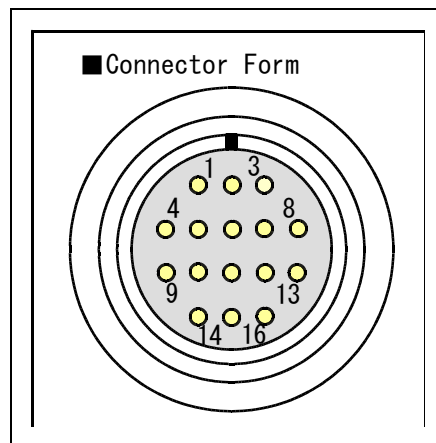

### ● RS-232C Format

1. Interfacing (Bit) Spec.
  - Start Bit : 1 bit
  - Date Length : 8 bit
  - Stop Bit : 1 bit
  - Parity : None
  - Baud Rate : 9600 BPS

# **Attonic**

**ATTONIC CO., LTD.**

600-5 HIGASHI TAKADACHO, TOYOHASHI  
AICHI 441-8115 JAPAN.

TEL : (0532)-41-5357

FAX : (0532)-41-4826

U R L : <http://www.attonic.co.jp>

E-mail : [info@attonic.co.jp](mailto:info@attonic.co.jp)